

# α ALPHA CBT-DT and CBT-GT

ALUMINIUM HOUSED  
HIGH POWER  
COMPACT BRAKE RESISTORS IP 21

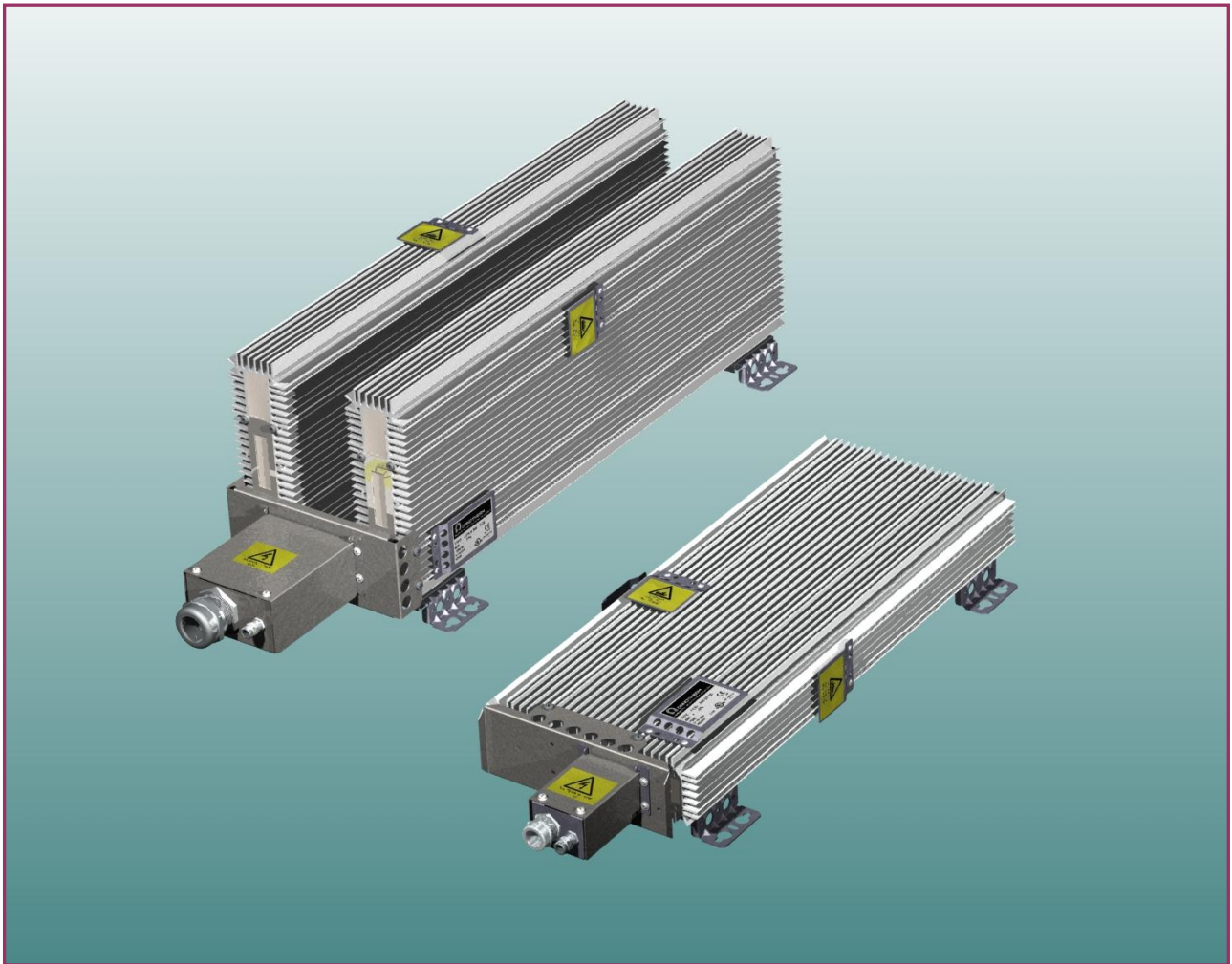

**CBT-H and CBT-V with integrated thermo watch** belonging to our high power range of **ALPHA ALUMINIUM HOUSED COMPACT BRAKE RESISTORS** are electrically insulated and can easily be integrated in compact constructions. They are specially constructed for high pulse loads compared to the average load.

The resistors comply with IP21 giving electrical and thermal protection. The resistors are Silicone free.

The power range is from 500 W to 5500 W steady state load and pulse loads of 60 times compared to the nominal load in

one second each 120s. (The power ratings are reduced compared to the resistors without thermostat.)

Danotherm has developed **thermal models** for all resistor types and resistor values. By using these models we are able to calculate the temperature rises in the resistor wire and on the surface for all possible load applications. We offer our assistance to our customers to find the optimum solution for any situation. All types can be offered with thermostats.

**ALPHA CBT DT** for connection up to 10 mm<sup>2</sup> and **CBT GT** for connection up to 50 mm<sup>2</sup> cables is a range of compact Aluminum Profile Brake Resistors with protection class IP21. The resistors are supplied with an internal thermostat and equipped with a connection box.

**Connection**

Power cables are connected through a M25 (M40 for G Type) cable gland with integrated screen (braid) connection. The power cables (0.75 – 10 mm<sup>2</sup>) or (2,5-50mm<sup>2</sup>) are connected to a terminal block with screw connections. The PE is connected directly to the connector box with a screw. The cable for the temperature switch is connected to a terminal block (0.5-4mm<sup>2</sup>) via a M12 gland with clamping range 3 – 7mm.

**CBT - - D -**  
Main Cable: 0.75 – 10 mm<sup>2</sup>  
Cable gland: Clamping Range: 9-16,6mmØ  
Braid diam: min 7,5 mmØ



**CBT - - G -**  
Main Cable: 2,5 - 50mm<sup>2</sup>.  
Cable gland: Clamping Range: 19-28 mmØ  
Braid diam: min 15 mmØ



**PULSE LOAD**

The curve show the pulse load ability compared to the nominal load for the CBT resistors under the following conditions: The load is a periodic pulse load with a constant **period time** of **120 sec** and a pulse width from **one second to 40 sec**.

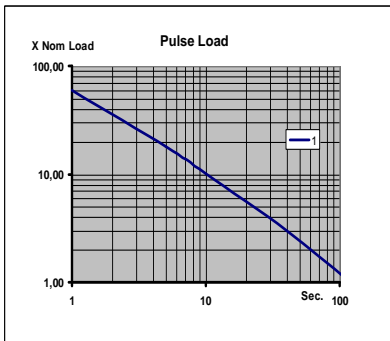

For all other load conditions please contact DANOTHERM. By mean of **individual thermal models** we can simulate the rises of temperatures in the components and on the surfaces during and between the specified pulses.

**Ratings: Resistors with 200°C T.W. (Short Pulse ratings depend on the resistance value.)**

CBT-V D(G) T	PN W @40°C According to UL508	Max Surface temp. °C @40°C	Pulse Load in 1 s each 120s. P1/120 kW @40°C	Pulse Load in 5 s each 120 s. P5/120 kW @40°C	Pulse Load in 10s each 120 s. P10/120 kW @40°C	Pulse Load in 40 s each 120 s P40/120 kW @40°C	Time Const. s (Steady state)	RΩ ±10%
CBT-H 180 D T 281	500	230	25.3	7.6	4.2	1.25	1000	0.2– 22
CBT-H 210 D T 281	700	230	35.5	10.6	5.6	1.75	1000	0.25– 40
CBT-H 260 D T 281	950	230	45.5	13.7	7.6	2.4	1000	0.33– 55
CBT-H 330 D T 281	1200	230	58.75	18	10	3	1000	0.5 – 75
CBT-H 400 D T 281	1400	240	72	22	12.3	3.7	10000	0.7–100
CBT-H 460 D T 281	1700	250	110	33.5	18.5	5.6	1000	0.8 –130
CBT-H 560 D T 281	2200	270	137	41	23	6.7	1000	1.0 –140
CBT-H 660 D T 281	2800	270	165	50	27	8.3	1000	1.4–150
CBT-H 760 D T 281	3200	280	192	57	32	9.5	1000	1.5– 160
CBT-V 460 D T 282	2800	240	220	65	35	9	1000	0.4 – 65
CBT-V 560 D T 282	3500	250	275	80	42	10.8	1000	0.5 – 70
CBT-V 660 D T 282	4200	275	300	100	52	13.5	1000	0.7 – 80
CBT-V 760 D T 282	5500	340	350	110	62	17	1000	0.75–85

General Specifications	
Temperature Coefficient:	≤±100ppm
Dielectric strength:	Standard: 2500VAC 1 minute
Working Voltage:	600VAC; 1100VDC
Isolation Resistance:	> 20 MΩ
Overload:	5-10x in10 sec; 25-35 x in 1 s
Environmental:	-40 °C – 90 °C
De-rating :	Linear: 40°C = P <sub>N</sub> to 70°C = 0.5*P <sub>N</sub>
Thermo watch contact	NC; 2A, 250V

PN: NOMINAL POWER WITH NATURAL COOLING and mounted in a vertical position. SURFACE TEMPERATURE:195°C @ 40°C AMB near Connector Box and Thermostat.

\*) Configuration: 281= ONE resistor profile; 282 = TWO resistor profiles, see below.

**D**

**G**

Type	L mm	L1 mm	W Kg	Type	L mm	L1 mm	W Kg
CBT-H 180 D/G H T 281	180	60	3.9	CBT-H 660 D/G H T 281	660	560	12.8
CBT-H 210 D/G H T 281	210	110	4.8	CBT-H 760 D/G H T 281	760	660	14.6
CBT-H 260 D/G H T 281	260	160	5.6				
CBT-H 330 D/G H T 281	330	230	6.9	CBT-V 460 D/G H T 282	460	360	18.4
CBT-H 400 D/G H T 281	400	300	8.2	CBT-V 560 D/G H T 282	560	460	22
CBT-H 460 D/G H T 281	460	360	9.2	CBT-V 660 D/G H T 282	660	560	25.5
CBT-H 560 D/G H T 281	560	460	11	CBT-V 760 D/G H T 282	760	660	29

**Type identification:**

Please specify your CBT Brake resistor as follows

**CBT-H 660 G H T 22R 2 8 1**

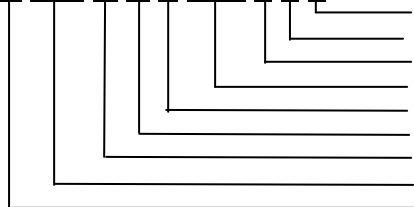

- Last digits XXX > 400: Customer specified version, otherwise **configuration**:
- Number of profiles **1** or **2**
- Thermo watch temperature: **5** = 130°C; **6** = 160°C; **7** = 180°C; **8** = 200°C; **0**: No T.W.
- Protection grid: **2** = No grid; **3** = Protection grid
- Ohm Value (Examples: **2R2** = 2.2Ω; **22R** = 22 Ω; **220R** = 220Ω; **1K0** = 1.0 kΩ )
- T**: Thermostat
- H**: Helix wire element (Specified by Danotherm)
- Connection Box: **D** = 10 mm<sup>2</sup>; **G** = 50 mm<sup>2</sup>
- Length of resistor profile in mm.
- H**: Horizontally mounted profile; **V**: Vertically mounted profile.