

α ALPHA CCH / CCR

ALUMINIUM HOUSED COMPACT BRAKE RESISTORS
WITH INTERNAL THERMO WATCH

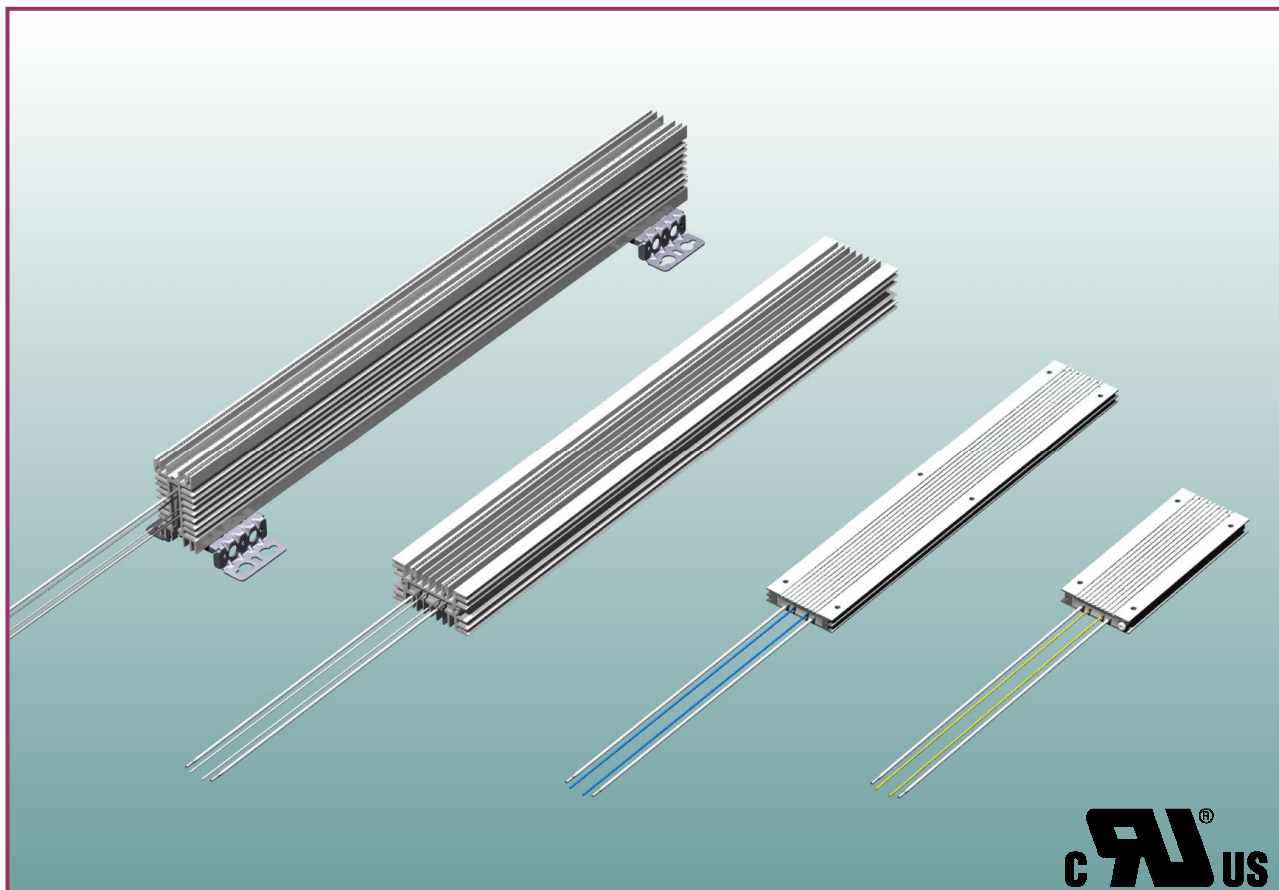

CCH and **CCR** with **internal thermo watch** belonging to our medium range of **ALUMINIUM HOUSED COMPACT ALPHA BRAKE RESISTORS** are electrically insulated and with small dimensions so that they can easily be fitted into compact constructions. They are especially designed to endure high pulse loads compared to the average load.

The steady state power range span from **80W** to **790W** and they can withstand pulse loads of up to 40 times these values for one second every 120 seconds! The very flat construction of CCH makes it ideal suitable for heat sink cooling and can be used in **liquid cooled** equipment. Improvements in the cooling of the resistor will naturally enhance its power capability.

Danotherm has developed **thermal models** for all resistor types and resistor values. By using these models we are able to predict the temperature rises of the resistor wire and of the surface for all possible load applications. We offer our assistance to our customers to find the optimum solution for any situation.

The CCH and CCR are available in two versions with different protection degrees: **IP50** or **IP65**. They are both Silicone free.

CCH and CCR are also available without internal thermo watch. Please see separate datasheet.

This range is generally approved to UL 508 (E208678). Please consult Danotherm.

Construction

The resistors are designed as follows:

The resistor elements are wire wound on mica support sheets. The outer housing is an aluminium profile insulated with micanite sheets on all inner surfaces. The resistor elements are fixed symmetrical in the profiles by the mica construction. This ensures a symmetric expansion of the resistors and a maximum stability to high load impulses. The resistor profile with the fixed resistor element is filled with quartz sand or MgO. This ensures a minimum change of temperature on the resistor surface even if the resistor element reaches its maximum temperature during a pulse load.

The standard cables are 300 mm AWG 16/14 Style 1659 PTFE, nature colour. We can supply cables in specified length, colours and mounted with cable shoes or connectors.

The resistors are approved to UL 508 for USA and Canada. All thermal data in this data sheet complies to UL 508 (no further reduction is required)

If screw terminals are required for the CCR types please use our **CCR-V XXX BT** or **CCR XXX DT** resistors with connection boxes.

If higher impulse or average load is required please consider the **CBR** or **CBT** types which have higher weight and thereby higher heat capacity / length.

Ratings:

TYPE CCH ...CT CCR ...CT	PN W @40°C Approved UL508 	Max Surface temp. °C @40°C	Pulse Load in 1s each 120s P1/120 kW @40°C	Pulse Load in 5s each 120s P5/120 kW @40°C	Pulse Load in 10s each 120s P10/120 kW @40°C	Pulse Load in 40s each 120s P40/120 W @40°C	Time Const sec.	R Ω (±5%) ±10%
CCH 145 CT	80	200	1.56	1.4	0.78	230	1000	2 - 1000
CCH 201 CT	120	205	2.5	2.25	1.25	370	1000	4 - 1200
CCH 251 CT	160	210	3.1	2.8	1.56	470	1000	6 - 1500
CCH 305 CT	200	210	3.9	3.5	1.99	600	1000	9 - 1700
CCH 355 CT	230	215	4.6	4.2	2.34	700	1000	10 - 2000
CCH 455 CT	300	220	6	5.4	3	910	1000	13 - 2000
CCH 555 CT	370	230	7.5	6.7	3.7	1120	1000	16 - 2000
CCH 655 CT	440	230	8.9	8	4.4	1330	1000	20 - 2000
CCR-V/CCR-H 145CT	140	230	3.4	1.9	0.91	410	1000	2 - 1000
CCR-V/CCR-H 201CT	190	250	8.3	2.6	1.9	760	1000	4 - 1200
CCR-V/CCR-H 251CT	250	255	11.8	3.4	2.8	990	1000	6 - 1500
CCR-V/CCR-H 305CT	300	260	13.7	4.1	3.4	1370	1000	9 - 1700
CCR-V/CCR-H 355CT	380	265	17.5	5.1	4.5	1520	1000	10 - 2000
CCR-V/CCR-H 455CT	480	275	21.3	6.5	5.3	2050	1000	13 - 2000
CCR-V/CCR-H 555CT	620	285	28.9	8.3	6.8	2660	1000	16 - 2000
CCR-V/CCR-H 655CT	790	290	32.7	10.7	8.3	3420	1000	20 - 2000

General Specifications

Temperature Coefficient:	<±100ppm
Dielectric strength:	2500VAC 1 minute
Working Voltage:	UL: 600VAC / CE: 690VAC; 1100VDC
Isolation Resistance:	> 20 MΩ
Overload:	10 x in10 s / 120 s; 40 x in 1 s / 120 s
Environmental:	-40 °C – 90 °C
De-rating :	Linear: 40°C = P _N to 90°C = 0.75*P _N
Thermo watch contact :	200°C (Optional 130°C/160°C/180°C), 2A, 250V, NC
Approvals	UL 508

PN: NOMINAL POWER WITH NATURAL COOLING WITH INTERNAL 200°C THERMO WATCH and:

CCH mounted in a horizontal position; CCR-V and CCR-H mounted in a vertical position.

For data for resistors without internal thermostats please ask for special data sheet.

Colour code for T.W. cables: 130°C: brown / 160°C: blue / 180°C: orange / 200°C: white

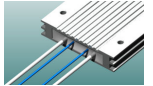

PULSE LOAD

The curve show the pulse load ability compared to the nominal load for the resistors under the following conditions: The load is a periodic pulse load with a constant period time of 120 seconds and a pulse width from 1 to 120 seconds.

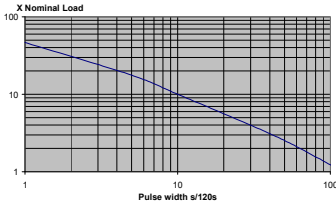

For further optimization DANOTHERM offers individual thermal electric circuit models for all types and ohm values. With these models can the temperature of the resistor wire and resistor surface be simulated during any pulse load conditions with a standard software like PSpice. Alternatively offers Danotherm to make thermal simulation for our customers

Mechanical Data

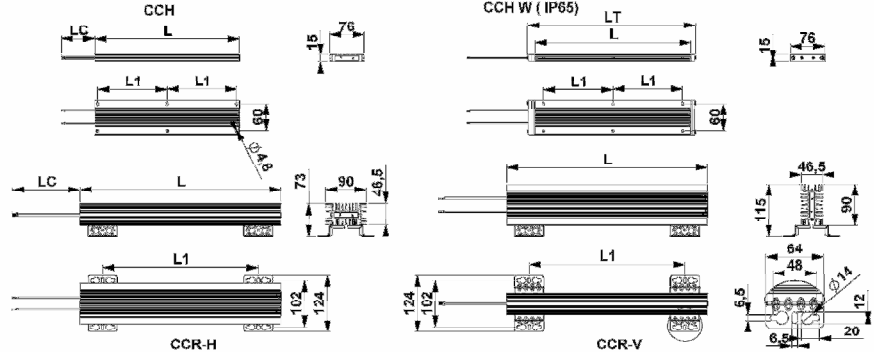

The total resistor length (LT) will in the IP 65 versions be 27mm longer than the profile length (L): **LT=L+27mm**. CCH and CCH W have the same distance L1 between the mounting points.

CCH for heat sink cooling requires extra mounting holes to assure sufficient thermal contact. The distance between mounting points (L1) should be about 100mm and can be made according to customer specification. The table shows our standard sizes, other sizes are possible. The weight in the table refers to IP 50 versions.

Type	L ±2mm	L1 ±0.5mm	Weight kg	Type	L ±2mm	L1 ±2mm	Weight kg
CCH 145 CT	145	98	0.27	CCR-V/CCR-H 145 CT	145	-	0.61
CCH 201 CT	201	154	0.41	CCR-V/CCR-H 201 CT	201	91	0.90
CCH 251 CT	251	204	0.54	CCR-V/CCR-H 251 CT	251	141	1.10
CCH 305 CT	305	258	0.62	CCR-V/CCR-H 305 CT	305	195	1.35
CCH 355 CT	355	2x154	0.85	CCR-V/CCR-H 355 CT	355	245	1.58
CCH 455 CT	455	2x204	1.11	CCR-V/CCR-H 455 CT	455	345	2.03
CCH 555 CT	555	2x241.5	1.36	CCR-V/CCR-H 555 CT	555	445	2.46
CCH 655 CT	655	2x291.5	1.61	CCR-V/CCR-H 655 CT	655	545	2.92

Type identification:

CCR-V 355 (M) C T 22R 081

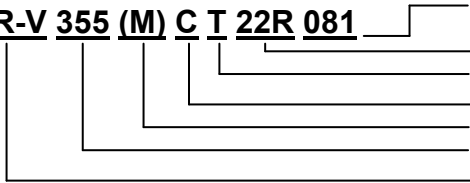

081 = Standard thermostat 200°C; **071** = 180°C; **061** = 160°C; **051** = 130°C; **XXX** > 400 customer specified version.

Ohm Value (Examples: 2R2=2.2Ω; 22R=22 Ω; 220R=220Ω; 2K2 = 2.2 kΩ)

T = Thermostat

Terminals: C: Cable, W: Cables and IP65 (UL: Type 4X)

M MgO filling, (specified by Danotherm)

Length of resistor profile in mm.

Type CCH, CCR-V, CCR-H

NON UL versions: CCHX 355 CT 22R 081